



Intertek

**BA2**

Bullstar AC series

**230 V 50–60 Hz****3 W AC LEDs****TECHNICAL****DATASHEET**

## INTRODUCTION

Octa Light high power AC LEDs represent an optimized solution for applications requiring no external power driver but direct AC input grid voltage. The BA2 series are optimized to bring high performance and quality of light needed for today's wide range of lighting applications, such as general, decorative, indoor, outdoor, industrial or commercial lighting etc. The BA2 AC series are intended for 230 V AC 50/60Hz direct operation without the need of any external converting power supply. The sunk current can be regulated with an external resistor in order to reach a specific consumption and lighting output.

In addition to delivering specified Correlated Color Temperature and Color Rendering combinations, the BA2 series emitters deliver excellent efficacy, lifetime and reliability. This document contains the performance data needed to design LED based applications.

### Octa Light BA2 Series Features

- Power supply – Direct AC LEDs
- Intended for 190V - 230V 50 Hz AC operation
- Max continuous average forward current up to 25 mA, max consumed power 5.5W
- Specified CCT & CRI combinations
- ANSI compliant Quarter binning
- LM80 Qualified
- Reflow process compatibility
- Optimized optical performance for higher light output compared to market competitors

# General Coding instructions for Octa Light BA2 LED series Product Binning and Labelling

## OCTL – BA2 – WW J – F 8A U – B 70 X1 X2 X3 X6 X4 X5 X7 X8 X9

X1 Comp. name	X2 Series name	X3 Color type	X4 Optical type	X5 Chromaticity coordinates BIN <sup>1</sup>	X6 Minimum Flux BIN (Lm)	X7 Testing current (mA)	X8 Vf range at nominal current (v)	X9 CRI range
OCTL	BA2	CW - Cool White	F - 110 deg Focused	1 (A, B, C, D, E, F, O) <sup>2</sup>	Z - 230	U - 15	A -	60 - >60
				2 (A, B, C, D, E, F, O)	C1 - 300		95-108	
				3 (A, B, C, D, E, F, O)	D1 - 400		70 - >70	
				4 (A, B, C, D, E, F, O)				
		NW - Neutral White		5 (A, B, C, D, E, F, O)	B -		200-240	80 - >80
				6 (A, B, C, D, E, F, O)				
				7 (A, B, C, D, E, F, O)				
				8 (A, B, C, D, E, F, O)				
WW - Warm White			90 - >90					
			95 - >95					

**Notes:**

- Information about chromaticity coordinates bin can be found in Binning information file.
- Chromaticity coordinates bin named X0 includes all of the ANSI sub-bins type XA, XB, XC, XD, XE, XF. This applies for all bins.
- All BA1 and BA2 Series LEDs are tested at AC current equal to the specified in column X8
- Octa Light maintains a +-5% measurement error on forward voltage and overall luminous output characteristics
- All binning at 25C Junction temperature.



## PRODUCT SELECTION

**Table 2.1 Product Selection for Octa Light BA2 Series LEDs- High lm/W range**  
 Example nomenclatures for Bullstar BA2 LED series with highest lm/W combinations

	Nominal CCT	Part Number	Minimum CRI	Typical CRI	Minimal Luminous Flux(lm) $\Phi_v$ @15mA	Typical Luminous Flux (lm) @ 15mA	Forward voltage range (50Hz or 60 Hz)
Warm White	2700K	OCTL-BA2-WWC1-F80U-B70	70	75	230	250	AC 190-216V
	3000 K	OCTL-BA2-WWC1-F70U-B70	70	75	230	250	AC 190-216V
	3500 K	OCTL-BA2-WWC1-F60U-B70	70	75	230	250	AC 190-216V
Neutral White	4000K	OCTL-BA2-NWC1-F50U-B70	70	75	300	320	AC 190-216V
	4500K	OCTL-BA2-NWC1-F40U-B70	70	75	300	320	AC 190-216V
Cool White	5000K	OCTL-BA2-CWC1-F30U-B70	70	75	300	320	AC 190-216V
	5700K	OCTL-BA2-CWC1-F20U-B70	70	75	300	320	AC 190-216V
	6500K	OCTL-BA2-CWC1-F10U-B70	70	75	300	320	AC 190-216V

**Table 2.2 Product Selection for Octa Light BA2 Series LEDs- High CRI range**  
 Example nomenclatures for Bullstar BA2 LED series with highest lm/W combinations

	Nominal CCT	Part Number	Minimum CRI	Typical CRI	Minimal Luminous Flux(lm) @15mA RMS	Typical Luminous Flux (lm) @ 15mA RMS	Forward voltage range
Warm White	2700K	OCTL-BA2-WWZ-F80U-B80	80	85	230	250	AC 190-216V
	3000 K	OCTL-BA2-WWZ-F70U-B80	80	85	230	250	AC 190-216V
	3500 K	OCTL-BA2-WWZ-F60U-B80	80	85	230	250	AC 190-216V
Neutral White	4000K	OCTL-BA2-NWC1-F50U-B80	80	85	300	320	AC 190-216V
	4500K	OCTL-BA2-NWC1-F40U-B80	80	85	300	320	AC 190-216V
Cool White	5000K	OCTL-BA2-CWC1-F30U-B80	80	85	300	320	AC 190-216V
	5700K	OCTL-BA2-CWC1-F20U-B80	80	85	300	320	AC 190-216V
	6500K	OCTL-BA2-CWC1-F10U-B80	80	85	300	320	AC 190-216V

## ELECTRICAL CHARACTERISTICS

*Characteristics at If = 15 mA RMS and thermal pad temperature 25°C:*

Table 3.

Color	Part Name	Forward Voltage Vf (V) @ 15 mA RMS			$\Delta V_f / \Delta T_j$ (mV/°C), at Im=50 $\mu$ A	Power factor (with external Resistor)	Rth j-c (°C/W)
		Min.	Typical	Max.			
Cool white	OCTL-BA2-CWX-F10U-BXX	190	200	216	- 54 mV/°C	0.85	9
	OCTL-BA2-CWX-F20U-BXX	190	200	216	- 54 mV/°C	0.85	9
	OCTL-BA2-CWX-F30U-BXX	190	200	216	- 54 mV/°C	0.85	9
Neutral white	OCTL-BA2-NWX-F40U-BXX	190	200	216	- 54 mV/°C	0.85	9
	OCTL-BA2-NWX-F50U-BXX	190	200	216	- 54 mV/°C	0.85	9
Warm white	OCTL-BA2-WWX-F60U-BXX	190	200	216	- 54 mV/°C	0.85	9
	OCTL-BA2-WWX-F70U-BXX	190	200	216	- 54 mV/°C	0.85	9
	OCTL-BA2-WWX-F80U-BXX	190	200	216	- 54 mV/°C	0.85	9



**Notes:**

1. Octa Light PLC maintains a tolerance of  $\pm 5\%$  on forward voltage measurements.
2. Based on order codes, Octa Light PLC can deliver a specific Vf binning range as follows:
  - a. Vf Range 100 -130 V @ 15mA – type A,, see column X8 in BA1/BA2 coding guidelines
  - b. Vf Range 200 -230 V @ 15mA – type B, see column X8 in BA1/BA2 coding guidelines

## ABSOLUTE MAXIMUM RATINGS

*Table 5. Absolute maximum ratings for thermal pad temperature 25 °C*

Parameter	Symbol	Max rate
RMS (root mean square) current	$I_{f_{RMS}}$	25 mA
Maximum Pulse current (20 mS pulse width, 10% duty cycle)	$I_{f_{peak}}$	30 mA
Maximal Led junction temperature	$T_{jmax}$	115 C
ESD sensitivity	V	Class 2 *
Operating Case temperature @ 15mA	$T_{cmax}$	-40 + 120
Soldering temperature	$T_{soldermax}$	280 C
Storage temperature	$T_{store}$	-40C to +80 C
Allowable Reflow cycles	/	3 times
Manual soldering time at 260°C(Max)	-	8 Sec.

\* ESD sensitivity CLASS II, human body model, ANSI/ESDA/JEDEC JS-001-2012

## THERMAL AND OPTICAL CHARACTERISTICS

*Table 5. Absolute maximum ratings for thermal pad temperature 25 °C*

Parameter	Symbol	Typical
Thermal resistance, junction to solder point	C/W	9
Viewing Angle Lambertian Distribution (FWHM)	Degrees	110 Focused *
Color Shift Versus angle $\Delta x$ and $\Delta y$ at 80 degree viewing angle, CIE 1931 Optical distribution type A	$\Delta x, \Delta y$	0.04, 0.06

\* See optical advantages sheet for more detailed information about distribution angle

## APPLICATION INSTRUCTIONS

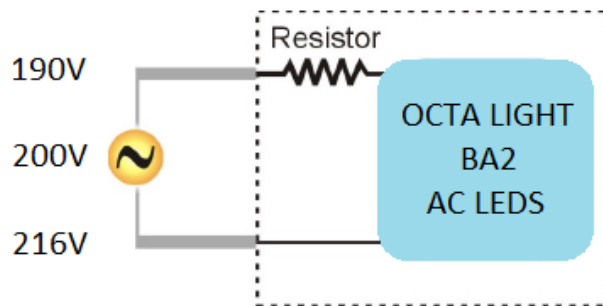

DIRECT AC LUMINAIRE

Notes: Ready tables with standard resistors values are available upon request



## RELATIVE SPECTRAL POWER DISTRIBUTION CHARACTERISTICS

*Warm White LED Relative spectral power distribution at 350mA test current*

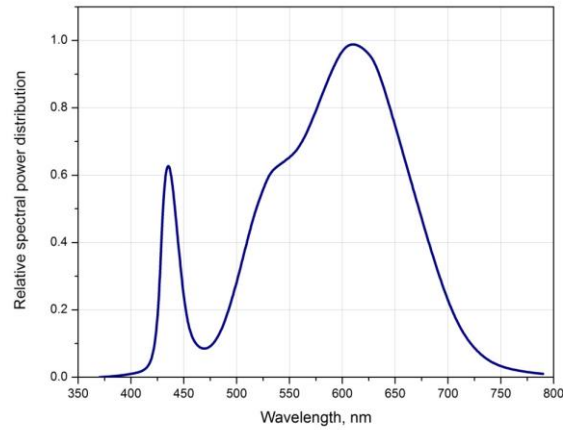

*Neutral White LED Relative spectral power distribution at 350mA test current*

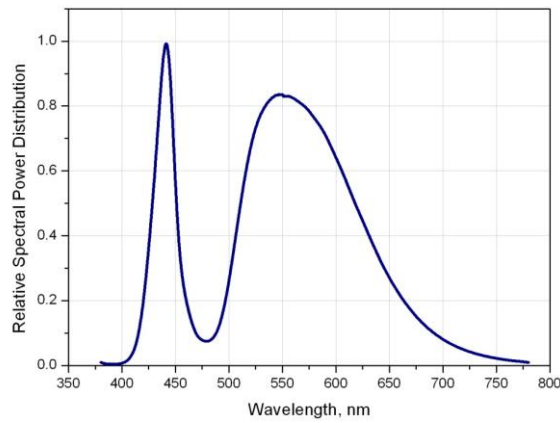

*Cool White LED Relative spectral power distribution at 350mA test current*

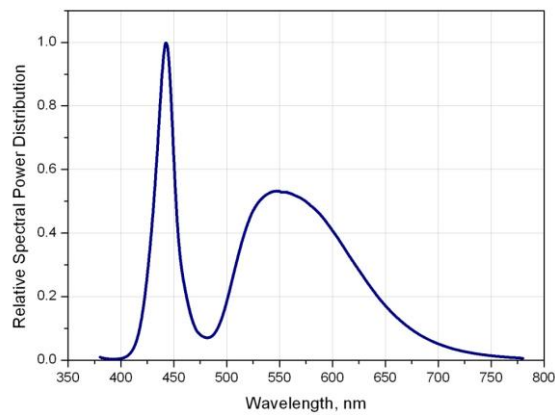



## LIGHT OUTPUT CHARACTERISTICS OVER TEMPERATURE

*Normalized Luminous Flux at 25°C,  $I_f = 15\text{mA RMS}$  and Std Dev.*

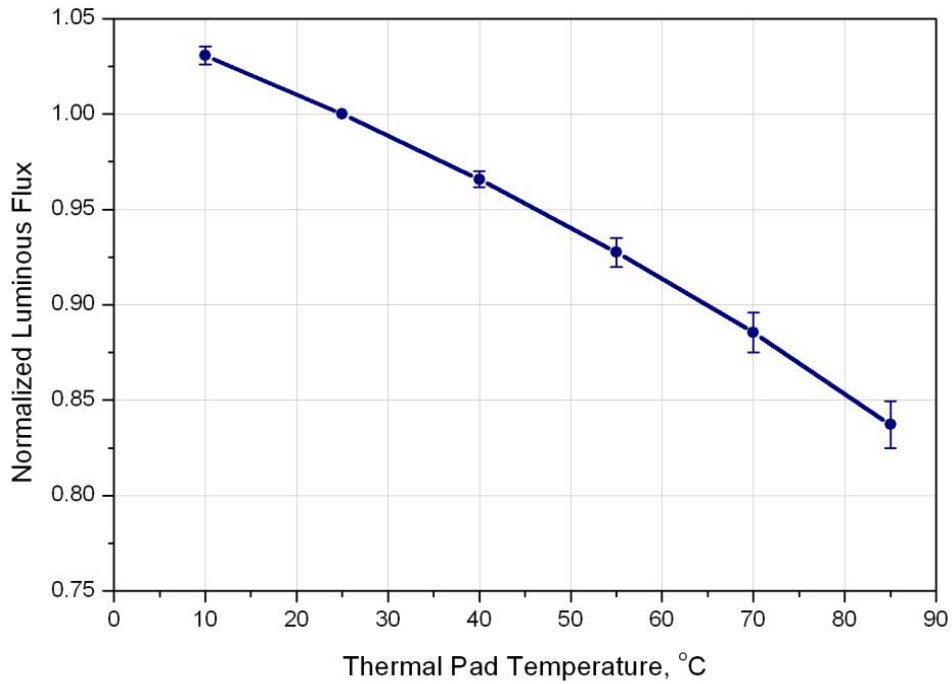

Figure 1. Relative Light output Vs. Thermal pad temperature

### Typical Color vs. Viewing Angle

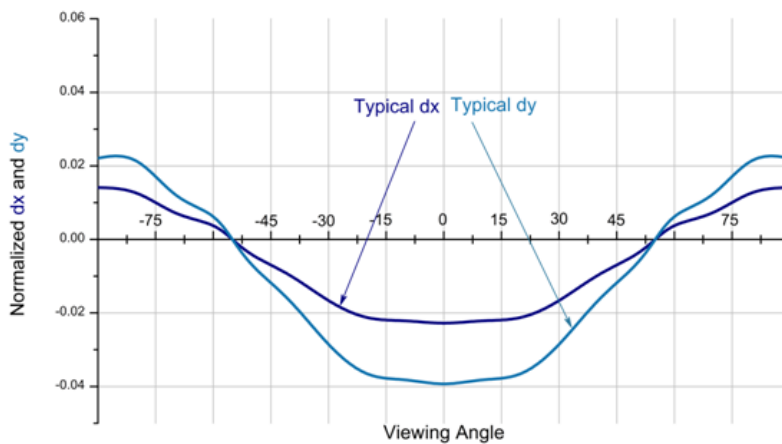

Figure 2. Maximal Color Shifting over viewing angle, normalized for 55 deg.



## EMISSION ANGLE CHARACTERISTICS

### *Typical Spatial Radiation Pattern*

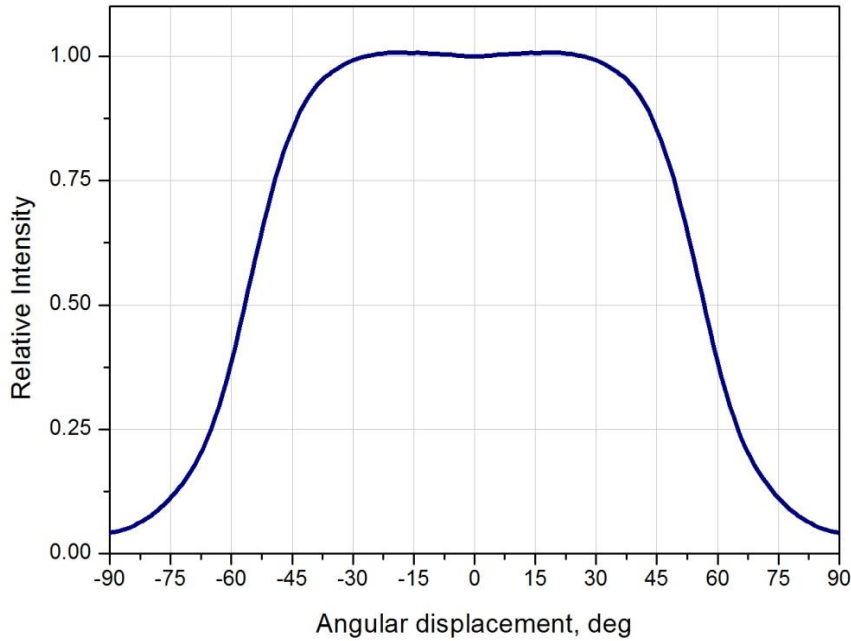

Figure 3. Typical representative spatial radiation pattern for 110° Focused

### *Typical Polar Radiation Pattern for Focus Optical Type*

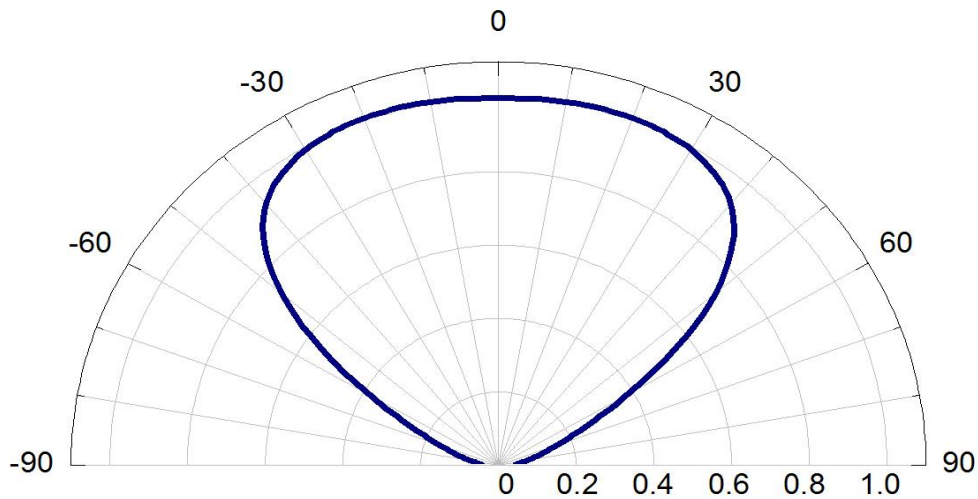
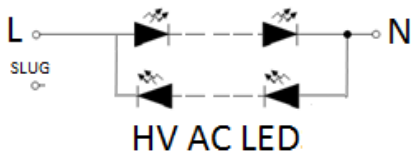
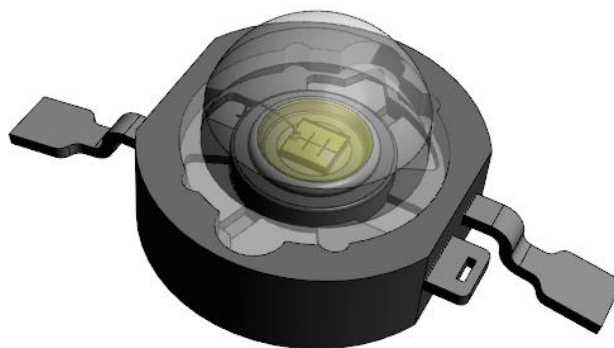
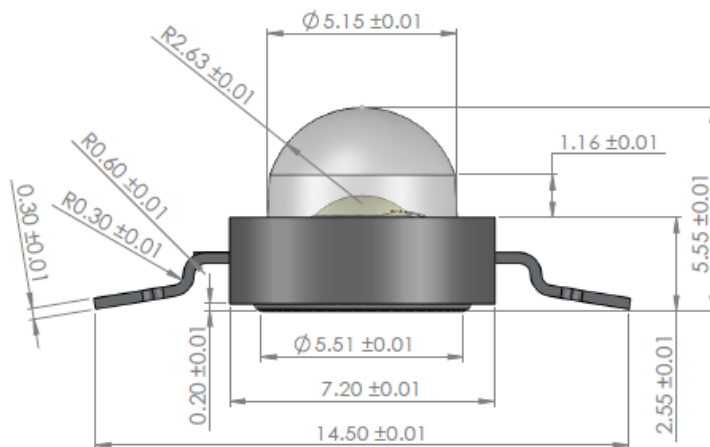
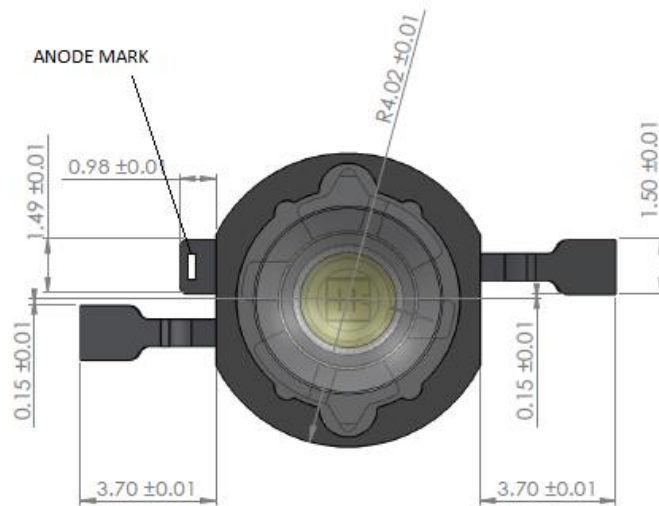

Figure 4. Typical representative polar radiation pattern for 110° Focused



## LED PACKAGE DIMENSIONS AND POLARITY



## OCTA LIGHT BA2 PACKAGE DIMENSIONS AND POLARITY

**Notes:**

1. All dimensions are in mm
2. Drawings are not to scale
3. All pictures are for dimensional reference only



PACKAGING INFORMATION  
TUBE DIMENSIONS

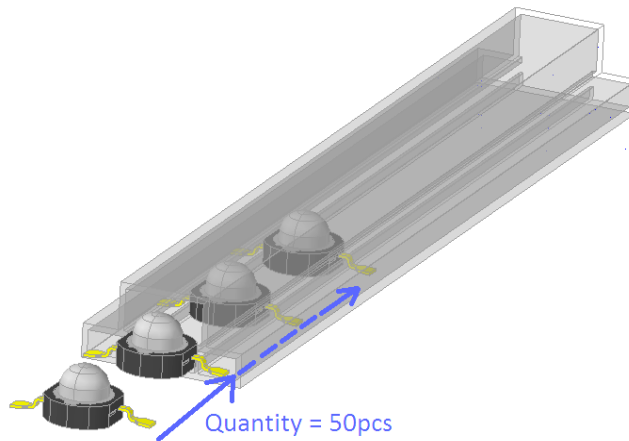
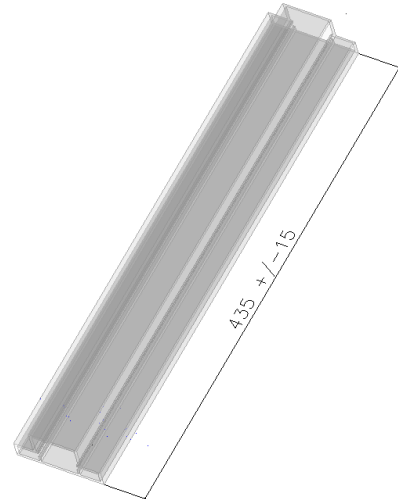
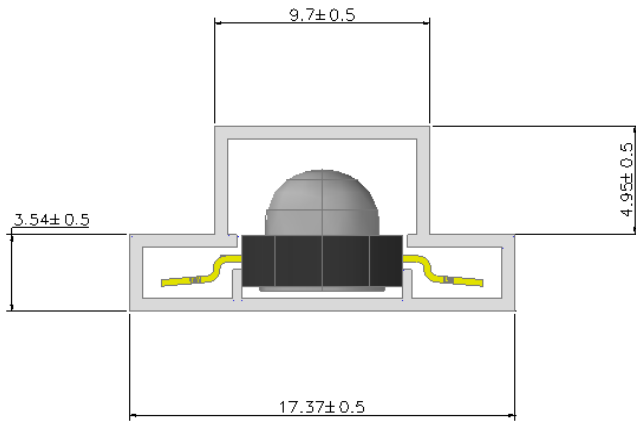

The label is placed on the back of each tube and contains product information and quantity of the LEDs inside.

LED PART NUMBER

QUANTITY



COMPANY INTERNAL INFORMATION

ROHS DIRECTIVE  
COMPLIANT

EUROPEAN  
COMMUNITY  
MARKS



## COMPANY INFORMATION

Octa Light Bulgaria was established in 2010 as a research and manufacturing center for Light Emitting Diodes (LED) and is entirely based in the EU. Octa Light Bulgaria own LED portfolio includes powerful high-brightness light emitting diodes, last generation of low-power & mid-power LEDs, wide range of COBs and innovative AC LED modules. The company manufactures LEDs in all three base colors - red, green, blue and white, as well as exotic colors as pink, cyan, yellow, purple and other on basis of client requirements. We constantly upgrade our LEDs range to bring highest performance and quality of light sources for today's wide range of lighting applications.

The company is also OEM and ODM supplier of LED packages.

Today Octa Light Bulgaria is fully vertically integrated manufacturer of LED packages, LED modules, LED lamps and LED luminaires.

Octa Light Bulgaria offers also complete lighting solutions accomplishing a variety of lighting projects with own range of LED luminaires. Further to its core lighting business the company offers Electronic Manufacturing Services (EMS).

[www.octa-light.com](http://www.octa-light.com)

[info@octa-light.com](mailto:info@octa-light.com)

©2014 Octa Light Bulgaria Plc

All rights reserved. Product specifications are subject to change without notice. Octa Light Bulgaria and its Company signs are registered trademarks in the European Union and other countries.