

**B9V**

series

## 1.5W, 9V HIGH POWER LED

## TECHNICAL DATASHEET

### INTRODUCTION

Octa Light high power B9V white LEDs are optimized to bring high performance and quality of light needed for today's wide range of lighting applications, such as general, decorative, indoor, outdoor, industrial or commercial lighting etc. In addition to delivering specified Correlated Color Temperature and Color Rendering combinations, BullStar series emitters deliver good efficacy, lifetime and reliability. This document contains the performance data needed to design LED based applications.

Unlike most fluorescent sources Octa Light Bullstar series LEDs contain no mercury and it is more energy efficient than incandescent and halogen light sources.

Octa Light B9V LED Series Features:

- Optimal forward voltage values - 9V directly drivable in 12V safe DC voltage applications
- High lumen output from a single source - up to 160 lumen at 150 mA, one single emitter
- Higher Light Density
- More light delivered at both low and high operating temperatures
- Specified CCT & CRI combinations
- ANSI compliant Quarter binning
- Exceed Energy Star® lumen maintenance requirements
- Low voltage operation and instant lighting
- Reflow process compatibility
- Optimized optical performance for higher light output compared to market competitors

## TABLE OF CONTENTS

Product Nomenclature.....	3
Environmental Compliance .....	3
Product Selection .....	4
Electrical Characteristics .....	5
Light output characteristics over temperature.....	6
Absolute Maximum Ratings .....	8
Relative Spectral Power Distribution Characteristics .....	9
Emission Angle Characteristics.....	10
LED Package Dimensions and Polarity.....	11
Packaging information.....	12
Company Information.....	13





PRODUCT SELECTION

Table 2.1

Product Selection for Octa Light B9V Series LEDs- **High lm/W range**

Example nomenclatures for B9V LEDs series with highest lm/W combinations

	Nominal CCT	Part Number	Minimum CRI	Typical CRI	Minimal Luminous Flux(lm) @ 150mA	Typical Luminous Flux (lm) @ 150mA	Forward voltage range @ 150mA
Warm White	2700K	OCTL-B9V-WWN-F80A-O170	70	75	130	135	8.0-11.2 V
	3000K	OCTL-B9V-WWN-F70A-O170	70	75	130	135	8.0-11.2V
	3500K	OCTL-B9V-WWN-F60A-O170	70	75	130	135	8.0-11.2V
Neutral White	4000K	OCTL-B9V-NWO-F50A-O170	70	75	140	145	8.0-11.2V
	4500K	OCTL-B9V-NWO-F40A-O170	70	75	140	145	8.0-11.2V
Cool White	5000K	OCTL-B9V-CWO-F30A-O170	70	75	150	155	8.0-11.2V
	5700K	OCTL-B9V-CWO-F20A-O170	70	75	150	155	8.0-11.2V
	6500K	OCTL-B9V-CWO-F10A-O170	70	75	150	155	8.0-11.2V

Table 2.2

Product Selection for Octa Light B9V Series LEDs- **High CRI range**

Example nomenclatures for B9V LEDs series with high lm/W and High CRI combinations

	Nominal CCT	Part Number	Minimum CRI	Typical CRI	Minimal Luminous Flux(lm) @150mA	Typical Luminous Flux (lm) @ 150mA	Forward voltage range @ 150mA
Warm White	2700K	OCTL-B9V-WWM-F80A-O180	80	85	120	125	8.0-11.2 V
	3000 K	OCTL-B9V-WWM-F70A- O180	80	85	120	125	8.0-11.2V
	3500 K	OCTL-B9V-WWM-F60A-O180	80	85	120	125	8.0-11.2V
Neutral White	4000K	OCTL-B9V-NWN-F50A-O180	80	85	130	135	8.0-11.2V
	4500K	OCTL-B9V-NWN-F40A-O180	80	85	130	135	8.0-11.2V
Cool White	5000K	OCTL-B9V-CWO-F30A-O180	80	85	140	145	8.0-11.2V
	5700K	OCTL-B9V-CWO-F20A-O180	80	85	140	145	8.0-11.2V
	6500K	OCTL-B9V-CWO-F10A-O180	80	85	140	145	8.0-11.2V

Table 2.3

Product Selection for Octa Light B9V Series LEDs - **Cost Efficiency Range**

Example nomenclatures for B9V LEDs series in the cost efficiency range

	Nominal CCT	Part Number	Minimum CRI	Typical CRI	Minimal Luminous Flux(lm) @ 150mA	Typical Luminous Flux (lm) @ 150mA	Forward voltage range @ 150mA
Warm White	2700K	OCTL-B9V-WWJ-F80C-O170	70	75	100	105	8.0-11.2 V
	3000 K	OCTL-B9V-WWJ-F70A-O170	70	75	100	105	8.0-11.2V
	3500 K	OCTL-B9V-WWJ-F60A-O170	70	75	100	105	8.0-11.2V
Neutral White	4000K	OCTL-B9V-NWK-F50A-O170	70	75	110	115	8.0-11.2V
	4500K	OCTL-B9V-NWK-F40A-O170	70	75	110	115	8.0-11.2V
Cool White	5000K	OCTL-B9V-CWK-F30A-O170	70	75	120	125	8.0-11.2V
	5700K	OCTL-B9V-CWK-F20A-O170	70	75	120	125	8.0-11.2V
	6500K	OCTL-B9V-CWK-F10A-O170	70	75	120	125	8.0-11.2V

Notes:

1. Octa Light maintains a tolerance of ±5% on forward voltage measurements.
2. All binning are at 25C color temperature



## ELECTRICAL CHARACTERISTICS

*Forward voltage characteristics at  $I_f = 150\text{ mA}$  and thermal pad temperature  $25^\circ\text{C}$ :*

Table 3.

Color	Part Name	Forward Voltage $V_f$ (V)			$\Delta V_f/\Delta T_j$ (mV/ $^\circ\text{C}$ ), at $I_m=5\text{mA}$	$R_{th\ j-c}$ ( $^\circ\text{C}/\text{W}$ )
		Min.	Typical	Max.		
Cool white	OCTL-B9V-CWN-F10C-XXX	8.4	9.6	10.5	2.1	5
	OCTL- B9V -CWN-F20C-XXX	8.4	9.6	10.5	2.1	5
	OCTL- B9V -CWN-F30C-XXX	8.4	9.6	10.5	2.1	5
Neutral white	OCTL- B9V -NWD-F40C-XXX	8.4	9.6	10.5	2.1	5
	OCTL- B9V -NWD-F50C-XXX	8.4	9.6	10.5	2.1	5
Warm white	OCTL- B9V -WWD-F60C-XXX	8.4	9.6	10.5	2.1	5
	OCTL- B9V -WWD-F70C-XXX	8.4	9.6	10.5	2.1	5
	OCTL- B9V -WWD-F80C-XXX	8.4	9.6	10.5	2.1	5

**Notes:**

1. Octa Light PLC maintains a tolerance of  $\pm 5\%$  on forward voltage measurements.
2. Based on order codes, Octa Light PLC can deliver a specific  $V_f$  binning range as follows:
  - a.  $V_f$  Range 2.8 -3.0 -  $V_f$  bin I, see column X8 in BST coding guidelines
  - b.  $V_f$  Range 3.0-3.2 -  $V_f$  Bin J, see column X8 in BST coding guidelines

*Forward voltage characteristics at  $I_f = 250\text{ mA}$  and thermal pad temperature  $25^\circ\text{C}$ :*

Table 4.

Color	Part Name	Forward Voltage $V_f$ (V)			$\Delta V_f/\Delta T_j$ (mV/ $^\circ\text{C}$ ), at $I_m=5\text{mA}$	$R_{th\ j-c}$ ( $^\circ\text{C}/\text{W}$ )
		Min.	Typical	Max.		
Cool white	OCTL- B9V -CWK-F10C	10.5	11.1	12	2.1	5
	OCTL- B9V -CWK-F20C	10.5	11.1	12	2.1	5
	OCTL- B9V -CWK-F30C	10.5	11.1	12	2.1	5
Neutral white	OCTL- B9V -NWJ-F40C	10.5	11.1	12	2.1	5
	OCTL- B9V -NWI-F50C	10.5	11.1	12	2.1	5
Warm white	OCTL- B9V -WWH-F60C	10.5	11.1	12	2.1	5
	OCTL- B9V -WWH-F70C	10.5	11.1	12	2.1	5
	OCTL- B9V -WWH-F80C	10.5	11.1	12	2.1	5

**Notes:**

Octa Light PLC maintains tolerance of  $\pm 5\%$  on forward voltage measurements.



*Light output characteristics over temperature*

At nominal current, normalized for 25 Degree Celsius

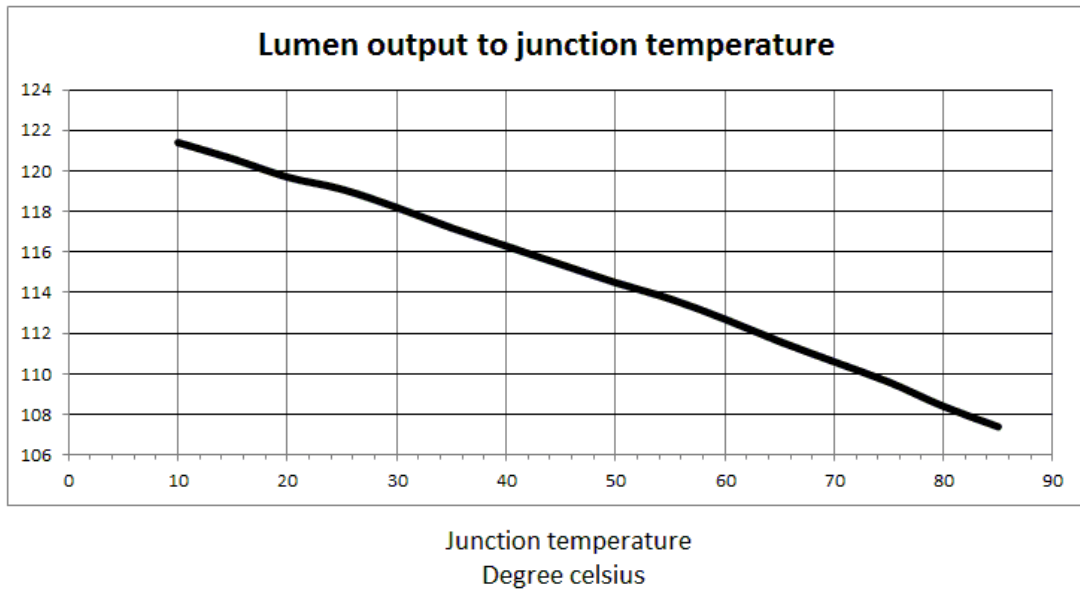

*Relative Luminous Flux from forward current at junction temperature 25 °C*

1= nominal lumen output for chosen Lumen bin

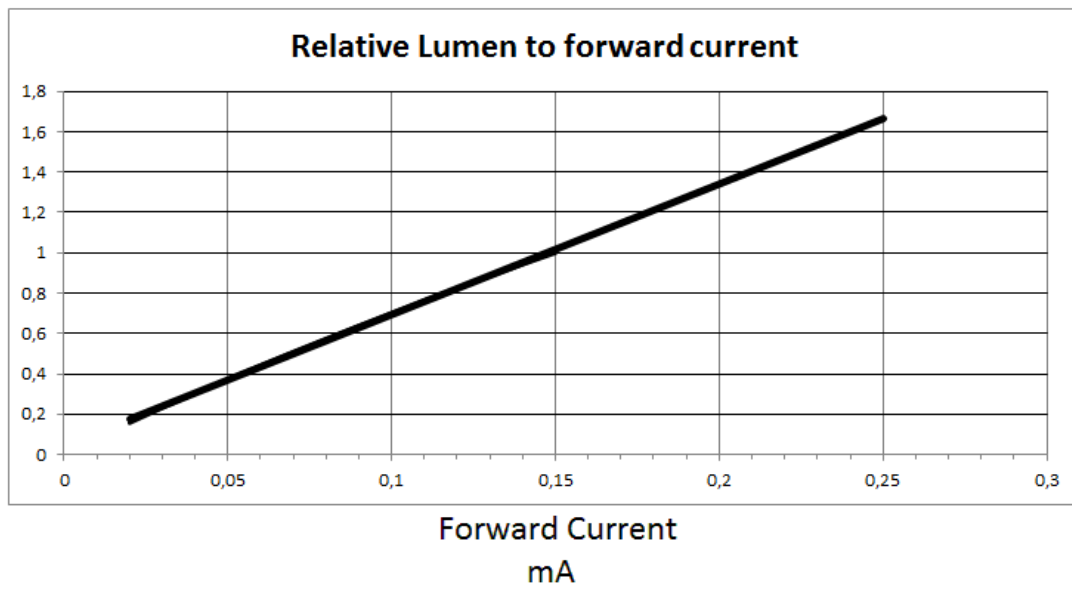



*Relative Lumen/W output from input power consumption at junction temperature 25 °C*

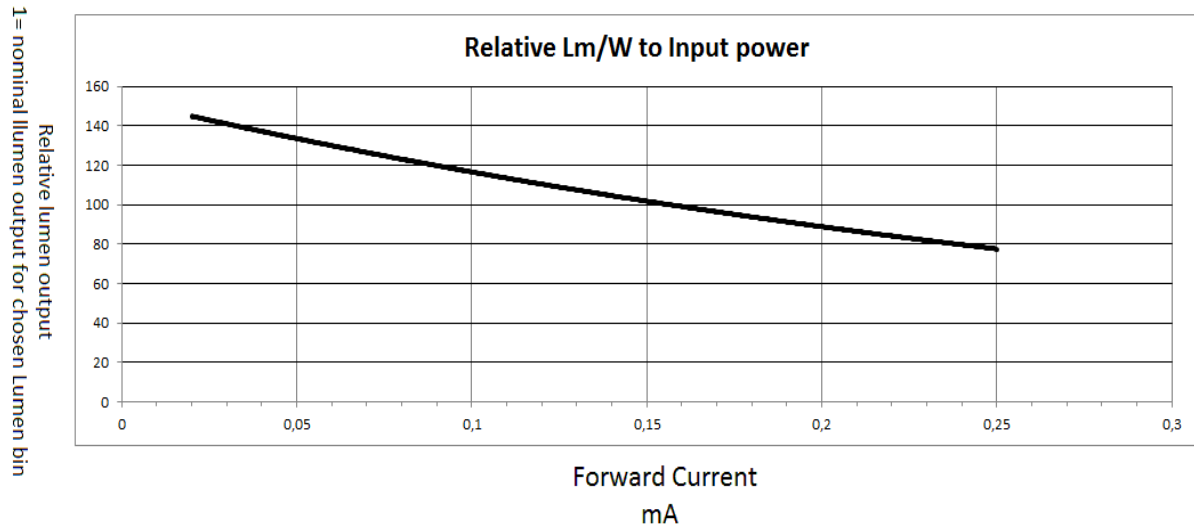

*Volt-Ampere characteristics at Junction temperature 25 °C*

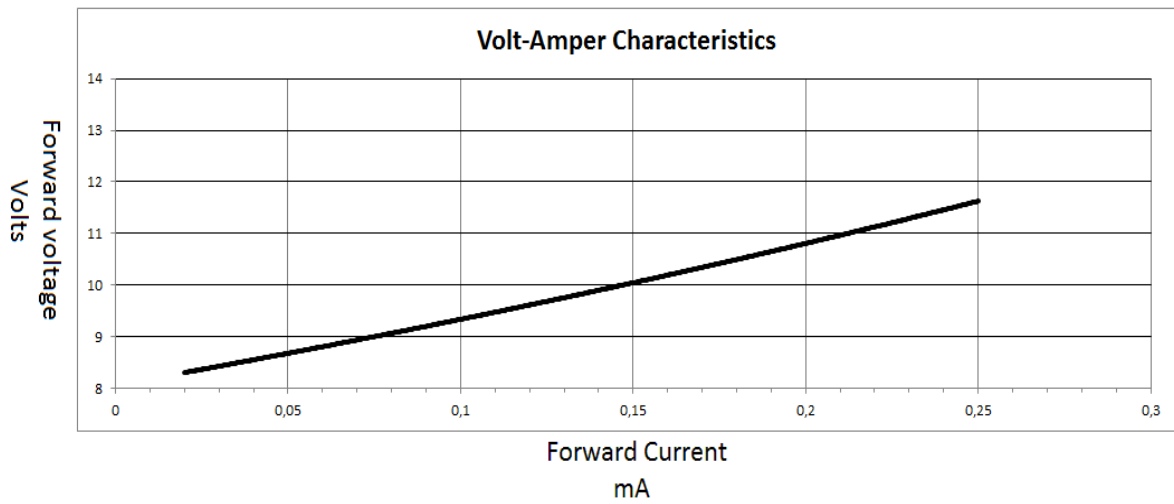



## ABSOLUTE MAXIMUM RATINGS

Table 5

Absolute maximum ratings at thermal pad temperature 25 °C

Parameter	Symbol	Max rate
Maximum DC forward current (continuous)	$I_{f_{max}}$	250 mA
Maximum Pulsed current (10 mS pulse width, 10% duty cycle)	$I_{f_{peak}}$	400 mA
Absolute Max forward voltage @ 350 mA	$V_{fmax}$ 400mA	4 V
Maximal Led junction temperature	$T_{jmax}$	150 C
ESD sensitivity	V	Class 2 *
Operating Case temperature @ 350mA	$T_{cmax}$	-60 + 140
Soldering temperature	$T_{soldermax}$	230 C **
Storage temperature	$T_{store}$	-40C to +120 C
Allowable Reflow cycles	/	3 times
Reverse voltage at maximal reverse current 10µA	$V_r$	5 V
Manual soldering time at 260°C(Max)	-	8 Sec.

\* ESD sensitivity CLASS II, human body model, ANSI/ESDA/JEDEC JS-001-2012

\*\* JEDEC 0200

## THERMAL AND OPTICAL CHARACTERISTICS

Table 6

Absolute maximum ratings for thermal pad temperature 25 °C

Parameter	Symbol	Typical
Thermal resistance, junction to solder point	C/W	5
Viewing Angle Lambertian Distribution (FWHM)	Degrees	110 Focused *
Color Shift Versus angle $\Delta x$ and $\Delta y$ at 80 degree viewing angle, CIE 1931 Optical distribution type A	$\Delta x, \Delta y$	0.03, 0.06

\* See optical advantage sheet for more detailed information about distribution angle

### Notes:

1. Octa Light PLC maintains a tolerance of  $\pm 5\%$  on forward voltage measurements.
2. Proper current derating must be observed to maintain junction temperature below the maximum at all time.
3. Light Emitting Diodes are not designed to be driven in reverse bias.
4. Allowable reflow cycles are 3 times for each LED. Maximum soldering temperature is not recommended to exceed 210°C, although the LED could withstand up to 230°C. For more information about reflow process profile and preferred soldering adhesives, please refer to Application datasheet.



# RELATIVE SPECTRAL POWER DISTRIBUTION CHARACTERISTICS

*Warm White LED Relative spectral power distribution at 350mA test current*

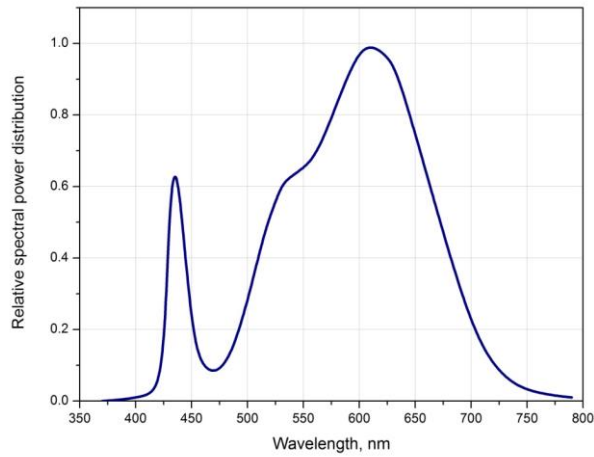

*Neutral White LED Relative spectral power distribution at 350mA test current*

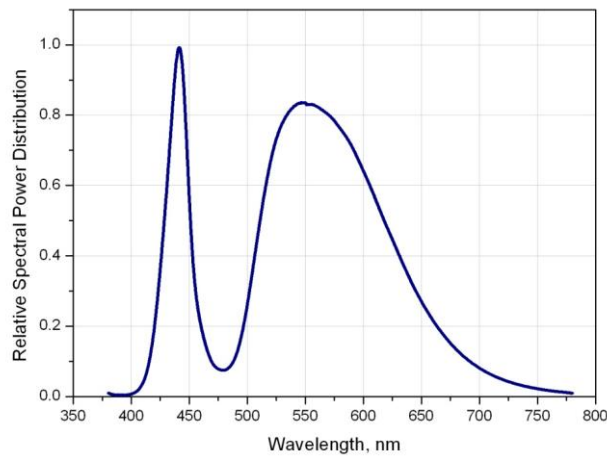

*Cool White LED Relative spectral power distribution at 350mA test current*

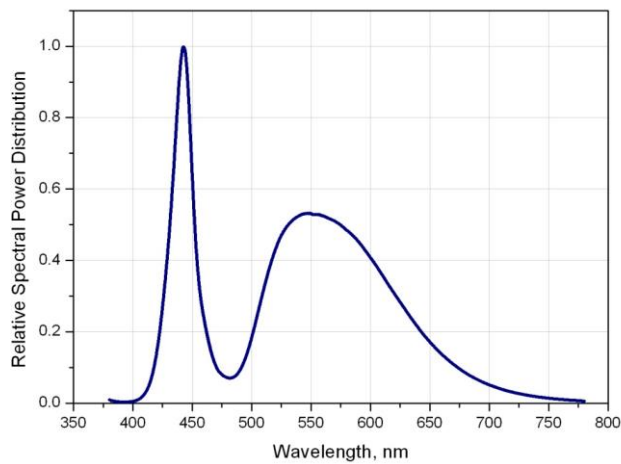



## EMISSION ANGLE CHARACTERISTICS

### *Typical Color vs. Viewing Angle*

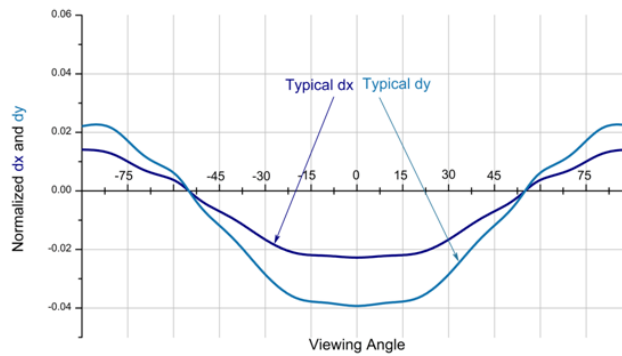

Maximal Color Shifting over viewing angle, normalized for 55 deg

### *Typical Spatial Radiation Pattern*

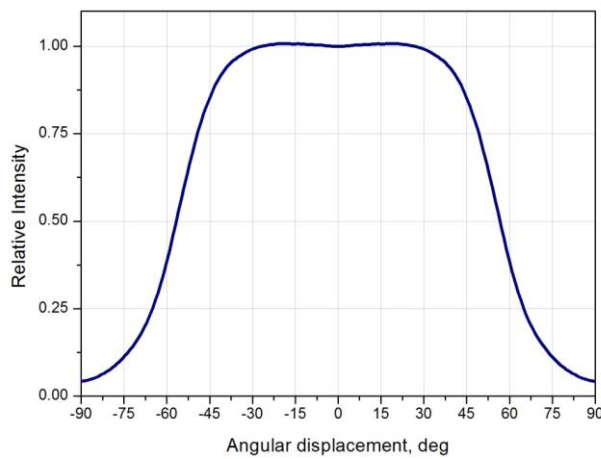

*Typical representative spatial radiation pattern for 110° Focused*

### *Typical Polar Radiation Pattern for Focus Optical Type*

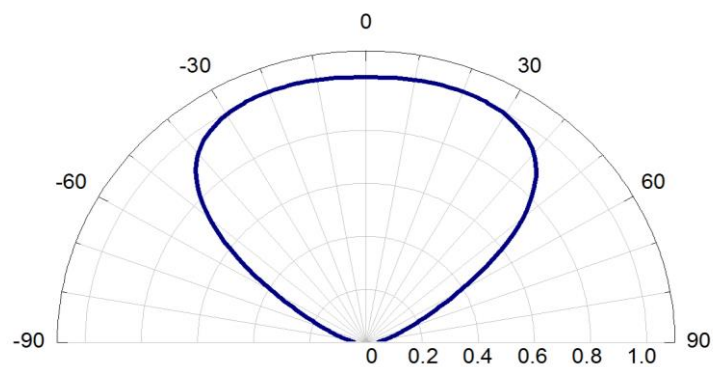

*Typical representative polar radiation pattern for 110° Focused*



## LED PACKAGE DIMENSIONS AND POLARITY

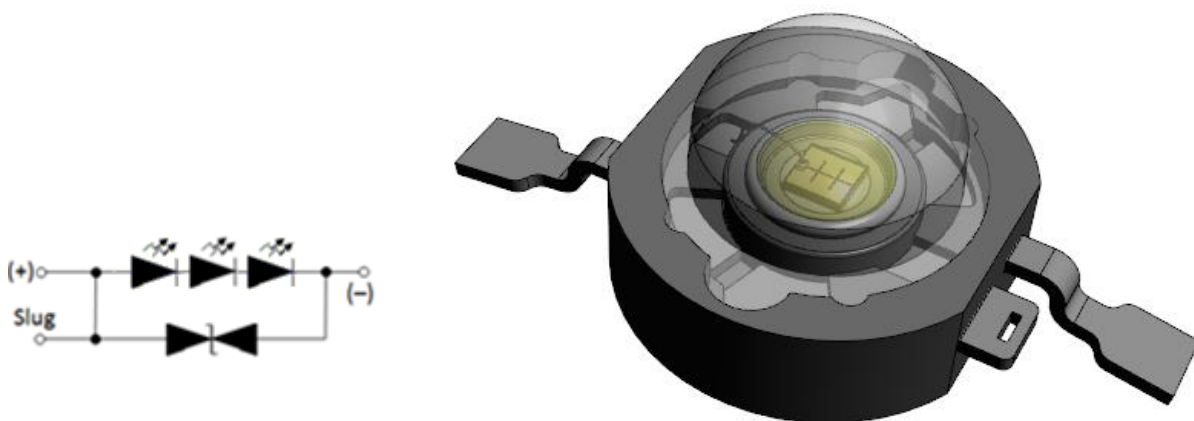
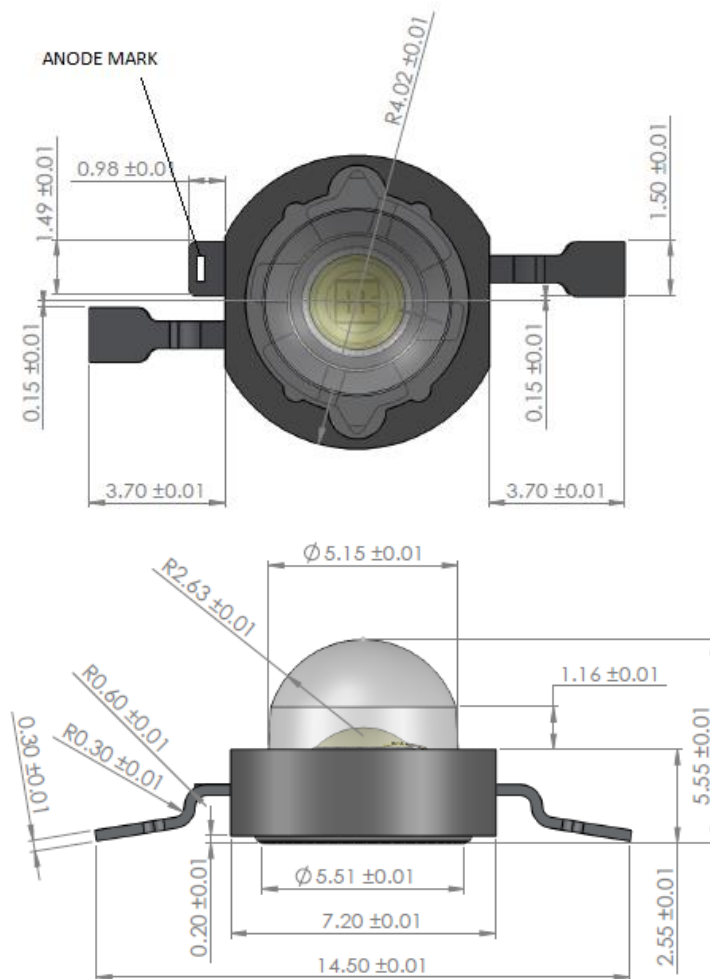

### OCTA LIGHT LED CIRCUITS

**Notes:**

1. All dimensions are in mm
2. Drawings are not to scale
3. Metal slug on bottom is electrically connected to Anode of the Light emitting device



# PACKAGING INFORMATION

## TUBE DIMENSIONS

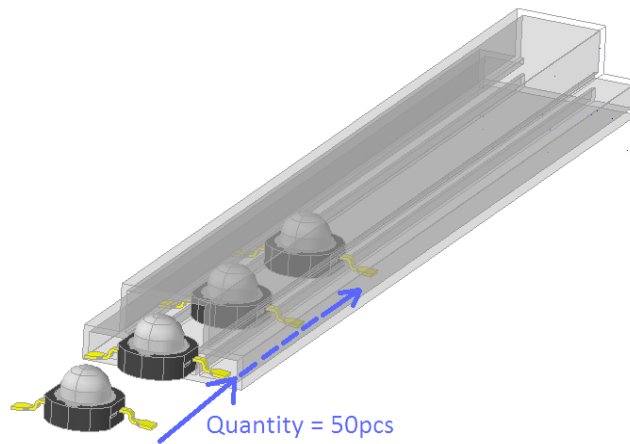
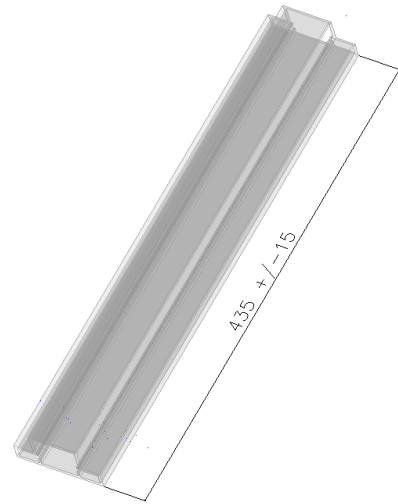
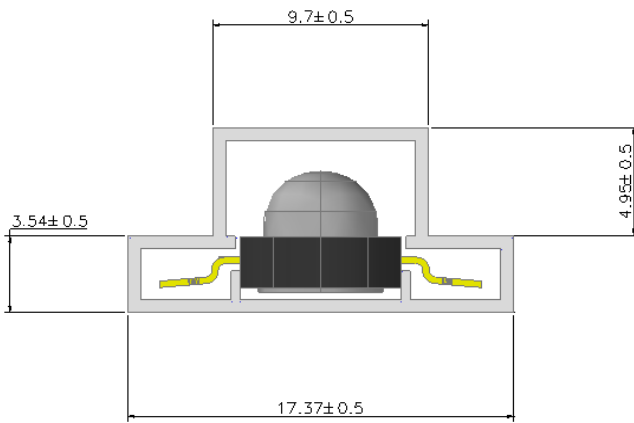

The label is placed on the back of each tube and contains product information and quantity of the LEDs inside.

LED PART NUMBER

QUANTITY



COMPANY INTERNAL INFORMATION

ROHS DIRECTIVE COMPLIANT

CE MARKING



## COMPANY INFORMATION

Octa Light Bulgaria Plc. is the first Bulgarian Manufacturer of High Power Light Emitting Diodes for general lighting applications. The long year company experience in artificial lighting on LED basis has made possible the creation of the first European LED specially designed for reaching best performance in light output, optical efficacy and thermal management.

Octa Light Products help reduce CO<sub>2</sub> emissions and reduce the need for power plant expansion.

Thanks to its advanced optical properties, the BullStar series enable never before possible applications in outdoor, indoor, industrial, architectural and general lighting when pure white light is necessary. The sophisticated optical properties allow strong package light concentration suitable for most general lighting applications without the need of any secondary optics.

Octa Light is a fully integrated supplier, offering core Light emitting devices in all three base colors - red, green, blue and white, as well as exotic colors as pink, cyan, yellow, purple and other on basis of client requirements. Octa Light Bulgaria Plc is entirely based within Europe, with R&D and manufacturing centers in Bulgaria. Founded in 2010, Octa Light commits to continuously rise the lumen efficiency of its products and to bring its light emitting diodes closer to mass usage within next years.

[www.octa-light.com](http://www.octa-light.com)

[info@octa-light.com](mailto:info@octa-light.com)

©2014 Octa Light Bulgaria Plc.

All rights reserved. Product specifications are subject to change without notice. Octa Light Bulgaria and its Company signs are registered trademarks in the European Union and other countries.