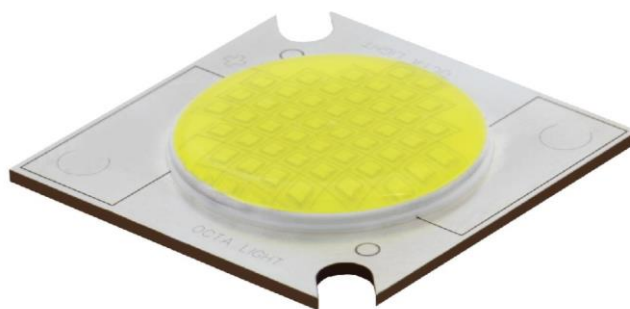

**Intertek**

TERMOQ C3F white

Octa Light Chip on Board Series

TECHNICAL DATASHEET

INTRODUCTION

Octa Light High Power Termoq COB Series is the new breakthrough technology for high density, high uniformity and long life high power Chip On Board modules.

All Octa Light COB LEDs provide industry highest thermal conductivity and biggest substrate stability due to its pure copper nature.

Octa Light COB LEDs are provided with standard ANSI binning, assuring close-up color choice according to application request.

Main features

- High thermal conductance (>400 W/mK) pure copper base, industry lowest thermal resistance packages.
- Supplied in
 - series connection - 25.6 V DC nominal @ test current 2100mA
- Supplied Bare, with EasySolder stack-up or standard holders assuring no need of connection wire soldering
- More light delivered at both low and high operating temperatures
- Specified CCT & CRI combinations
- ANSI compliant Quarter binning
- Exceed Energy Star® lumen maintenance requirements
- Low voltage operation and instant lighting
- Reflow process compatibility
- Optimized optical performance for higher light output in comparison to market competitors

TABLE OF CONTENTS

Product Nomenclature	3
Environmental Compliance	3
Product Selection	4
Electrical Characteristics	5
Absolute Maximum Ratings	5
Thermal and optical characteristics.....	6
JEDEC moisture sensitivity.....	6
Reflow soldering characteristics	6
Relative Spectral Power Distribution Characteristics	7
Light Output Characteristics Over Temperature	9
LED Package Dimensions and Polarity	11
Packaging Information.....	12
Company Information	14



General Coding instructions for Octa Light
C3F LED series
Product Binning and Labelling

OCTL-C3F-WW E2 - F 8A K - T 70
X1 X2 X3 X6 X4 X5 X7 X8 X9

Table 1

X1 Comp. name	X2 Series name	X3 Color type	X4 Optical type	X5 Chromaticity coordinates BIN ¹	X6 Minimum Flux BIN (Lm)	X7 Testing current (mA)	X8 Vf range at nominal current	X9 CRI range
OCTL	C3F	CW - Cool White	A - 120 deg Lambertian	1 (A, B, C, D, E, F, O) ²	C2 - 3000	K - 2 100	R-19.6 - 23.8	60 -> 60
		NW - Neutral White	B - Batwing	2 (A, B, C, D, E, F, O)	D2 - 4000		S-23.8 - 28.0	70 -> 70
		WW - Warm White	C - 100 deg Lambertian	3 (A, B, C, D, E, F, O)	E2 - 5000			80 -> 80
		BL - Blue	E - Side Emitting	4 (A, B, C, D, E, F, O)	F2 - 6000			90 -> 90
		RD - Red	F - 110 deg Focused	5 (A, B, C, D, E, F, O)	G2 - 7000			95 -> 95
		YE - Yellow	L - 140 deg Lambertian	6 (A, B, C, D, E, F, O)	H2 - 8000			
		GN - Green		7 (A, B, C, D, E, F, O)				
		CL - Color		8 (A, B, C, D, E, F, O)				
				BL (Blue)				
				RB (Royal Blue)				
				RD (Red)				
				RO (Red- Orange)				
				OR (Orange)				
				AM (Amber)				
		GN (Green)						
		CL (Color, for RGB)						

Notes:

1. Information about chromaticity coordinates bin can be found in Binning information file.
2. Chromaticity coordinates bin 10 includes all of the bins 1A, 1B, 1C, 1D, 1E, 1F. This applies for all bins.
3. * stands for future products

ENVIRONMENTAL COMPLIANCE

Octa Light COB SERIES LEDs are compliant to the Restriction of Hazardous Substances Directive - RoHS. The restricted materials including lead, mercury cadmium hexavalent chromium, polybrominated bipheyls (PBB) and polybrominated diphenyl ether (PBDE) are not used in Octa Light COB Series LEDs to provide an environment friendly product to the customers.



PRODUCT SELECTION

Table 2.1

Product Selection for Octa Light C3F Series LEDs- **High lm/W range**

Example nomenclatures for C3F LEDs series with highest lm/W combinations

	Nominal CCT	Part Number	Minimum CRI	Typical CRI	Minimal Luminous Flux (lm) @2100mA	Typical Luminous Flux (lm) @2100mA	Forward voltage range
Warm White	2700K	OCTL-C3F-WWE2-A80K-R70	70	75	5000	5400	19.6 - 23.8 V
	3000 K	OCTL-C3F-WWE2-A70K- R70	70	75	5000	5400	19.6 - 23.8 V
	3500 K	OCTL-C3F-WWE2-A60K- R70	70	75	5000	5400	19.6 - 23.8 V
Neutral White	4000K	OCTL-C3F-NWKE2-A50K- R70	70	75	5000	5800	19.6 - 23.8 V
	4500K	OCTL-C3F-NWE2-A40K- R70	70	75	5000	5800	19.6 - 23.8 V
Cool White	5000K	OCTL-C3F-CW F2-A30K- R70	70	75	6000	6400	19.6 - 23.8 V
	5700K	OCTL-C3F-CW F2-A20K- R70	70	75	6000	6400	19.6 - 23.8 V
	6500K	OCTL-C3F-CWF2-A10K- R70	70	75	6000	6400	19.6 - 23.8 V

Table 2.2

Product Selection for Octa Light C3F Series LEDs- **High CRI range**

Example nomenclatures for C3F LEDs series with high lm/W and High CRI combinations

	Nominal CCT	Part Number	Minimum CRI	Typical CRI	Minimal Luminous Flux(lm) @2100mA	Typical Luminous Flux (lm) @2100mA	Forward voltage range
Warm White	2700K	OCTL- C3F -WWD2-A80G-R80	80	85	4000	4600	19.6 - 23.8 V
	3000 K	OCTL- C3F -WWD2-A70G- R80	80	85	4000	4600	19.6 - 23.8 V
	3500 K	OCTL- C3F -WWD2-A60G- R80	80	85	4000	4600	19.6 - 23.8 V
Neutral White	4000K	OCTL- C3F -NWE2-A50G- R80	80	85	5000	5200	19.6 - 23.8 V
	4500K	OCTL- C3F -NWE2-A40G- R80	80	85	5000	5200	19.6 - 23.8 V
Cool White	5000K	OCTL- C3F -CWF2-A30G- R80	80	85	5000	5800	19.6 - 23.8 V
	5700K	OCTL- C3F -CWF2-A20G- R80	80	85	5000	5800	19.6 - 23.8 V
	6500K	OCTL- C3F -CWF2-A10G- R80	80	85	5000	5800	19.6 - 23.8 V

Table 2.3

Product Selection for Octa Light C3F Series LEDs- **Cost Efficiency Range**

	Nominal CCT	Part Number	Minimum CRI	Typical CRI	Minimal Luminous Flux(lm) @2100mA	Typical Luminous Flux (lm) @2100mA	Forward voltage range
Warm White	2700K	OCTL- C3F -WWC2-A80G-R70	70	75	3000	3200	19.6 - 23.8 V
	3000 K	OCTL- C3F -WWC2-A70G- R70	70	75	3000	3200	19.6 - 23.8 V
	3500 K	OCTL- C3F -WWC2-A60G- R70	70	75	3000	3200	19.6 - 23.8 V
Neutral White	4000K	OCTL- C3F -NWC2-A50G- R70	70	75	3000	3600	19.6 - 23.8 V
	4500K	OCTL- C3F -NWC2-A40G- R70	70	75	3000	3600	19.6 - 23.8 V
Cool White	5000K	OCTL- C3F -CWD2-A30G- R70	70	75	4000	4500	19.6 - 23.8 V
	5700K	OCTL- C3F -CWD2-A20G- R70	70	75	4000	4500	19.6 - 23.8 V
	6500K	OCTL- C3F -CWD2-A10G- R70	70	75	4000	4500	19.6 - 23.8 V

Notes:

1. Octa Light PLC maintains tolerance of $\pm 5\%$ on forward voltage measurements.
2. All binnings are at 25°C color temperature



ELECTRICAL CHARACTERISTICS

*Forward voltage characteristics for series connection,
Test current $I_f = 2100$ mA and thermal pad temperature 25°C .*

Table 3.

Color	Part Name	Forward Voltage V_f (V)			$\Delta V_f/\Delta T_j$ (mV/ $^\circ\text{C}$), at $I_m=30\text{mA}$	$R_{th\ j-c}$ ($^\circ\text{C}/\text{W}$)
		Min.	Typical	Max.		
Cool white	OCTL-C3F - WWX-A80G-X70	22.4	25.6	28	16	1.2
	OCTL-C3F - WWX-A70G- X70	22.4	25.6	28	16	1.2
	OCTL- C3F -WWX-A60G-X70	22.4	25.6	28	16	1.2
Neutral white	OCTL- C3F - NWX-A50G- X70	22.4	25.6	28	16	1.2
	OCTL- C3F - NWX-A40G- X70	22.4	25.6	28	16	1.2
Warm white	OCTL- C3F - CWX-A30G- X70	22.4	25.6	28	16	1.2
	OCTL- C3F - CWX-A20G- X70	22.4	25.6	28	16	1.2
	OCTL- C3F - CWX-A10G- X70	22.4	25.6	28	16	1.2

Notes:

1. Octa Light PLC maintains tolerance of $\pm 5\%$ on forward voltage measurements.
2. Based on order codes, Octa Light PLC can deliver a specific V_f binning range as follows:
 - a. V_f Range 19.6 - 23.8 - V_f bin R, see column XB in C3F coding guidelines
 - b. V_f Range 23.8 - 28.0 - V_f bin S, see column XB in C3F coding guidelines

ABSOLUTE MAXIMUM RATINGS

Table 4.

*Absolute maximum ratings for thermal pad temperature 25°C ,
Series connection test current 2100mA*

Parameter	Symbol	Max rate
Maximum DC forward current (continuous)	$I_{f\max}$	4 200 mA
Maximum pulse current (10 mS pulse width, 10% duty cycle)	$I_{f\text{peak}}$	4 800 mA
Absolute Max forward voltage @ 2100 mA	$V_{f\max\ 2100\text{mA}}$	30 V
Maximal Led junction temperature	$T_{j\max}$	150°C
ESD sensitivity	V	Class 2 *
Operating Case temperature at 2100mA	$T_{c\max}$	$-60^\circ + 140^\circ$
Soldering temperature	$T_{\text{soldermax}}$	260°C^{**}
Storage temperature	T_{store}	-40°C to $+120^\circ\text{C}$
Allowable Reflow cycles	/	3 times
Reverse voltage at maximal reverse current $10\mu\text{A}$	V_r	15 V

* ESD sensitivity CLASS II, human body model, ANSI/ESDA/JEDEC JS-001-2012

** JEDEC 020D



THERMAL AND OPTICAL CHARACTERISTICS

Table 5.

Absolute maximum ratings for thermal pad temperature 25 °C

Parameter	Symbol	Typical
Thermal resistance, junction to solder point	C/W	1.2
Viewing Angle Lambertian Distribution (FWHM)	Degrees	120
Color Shift Versus angle Δx and Δy at 80 degree viewing angle, CIE 1931 Optical distribution type A	$\Delta x, \Delta y$	0.04, 0.04

JEDEC MOISTURE SENSITIVITY

Table 6.

LEVEL	Floor Life		Soak Requirements	
	Time	Condition	Time	Condition
3	168 hours	30, 60% RH	192 Hrs +5 -0 Hrs	30°C 62% RH

REFLOW SOLDERING CHARACTERISTICS

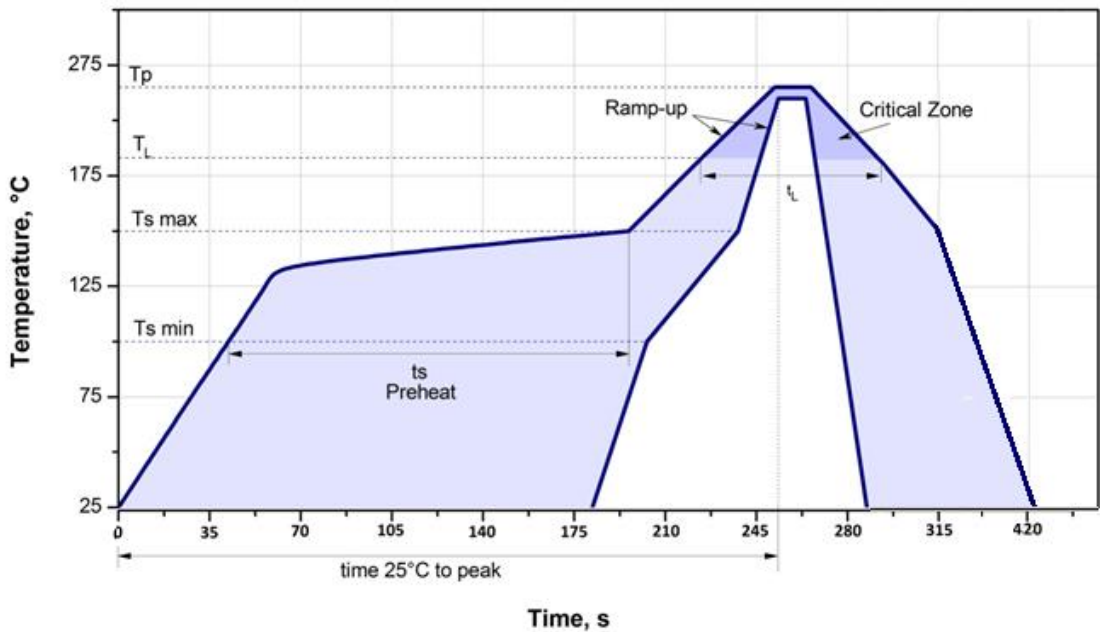

Figure 1.
Reflow Soldering Profile



Table 7.
Reflow Profile Features

Profile Feature	Assembly
Average Ramp-up rate (T _{smax} to T _p)	3°C/second max.
Preheat:	
- Temperature Min (T _{smin})	100°C
- Temperature Max (T _{smax})	150°C
- Time (T _{smin} to T _{smax})	60-120 seconds
Liquidous Temperature T _L	220°C
Maximum maintained time Time t _L	60-120 seconds
Absolute Maximum Peak package body Temperature (T _p)	260°C
Recommended Peak Package temperature	240°C
Time within 5°C of recommended Peak Package temperature (t _p)	10-30 seconds
Ramp-down rate	6°C/second max
Time 25°C to peak temperature	7 minutes max.

Relative Spectral Distribution (mW Versus Wavelength)

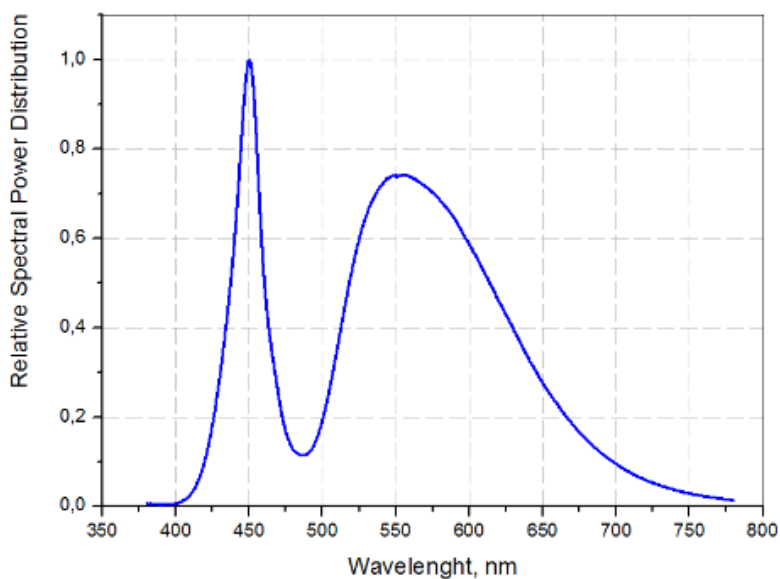

Figure 2.
Relative Cool White Spectral power distribution

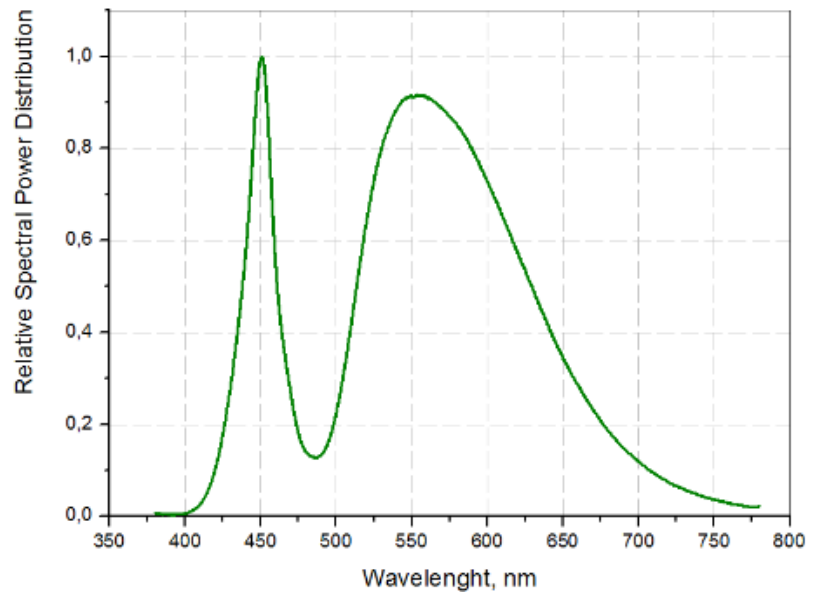

Figure 3.
Relative Neutral White Spectral power distribution

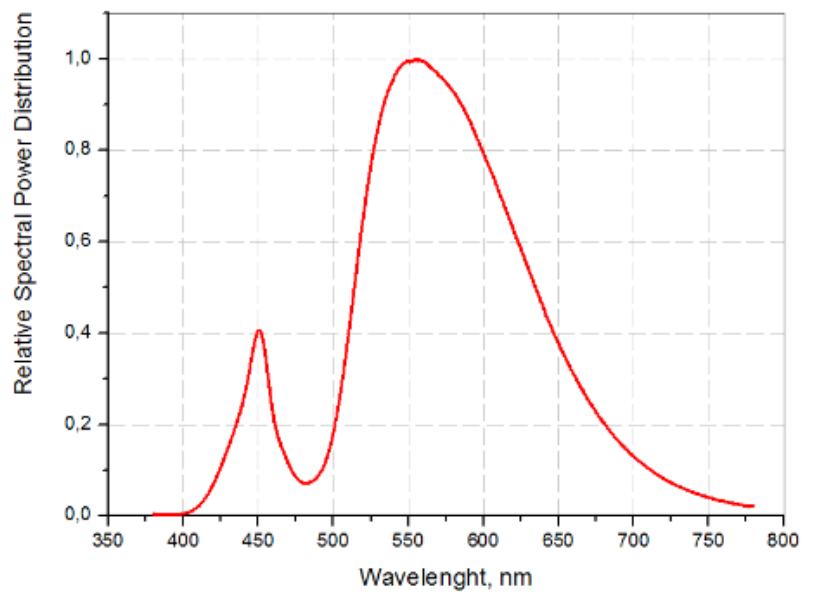

Figure 4.
Relative Warm White Spectral power distribution



Light output characteristics over temperature

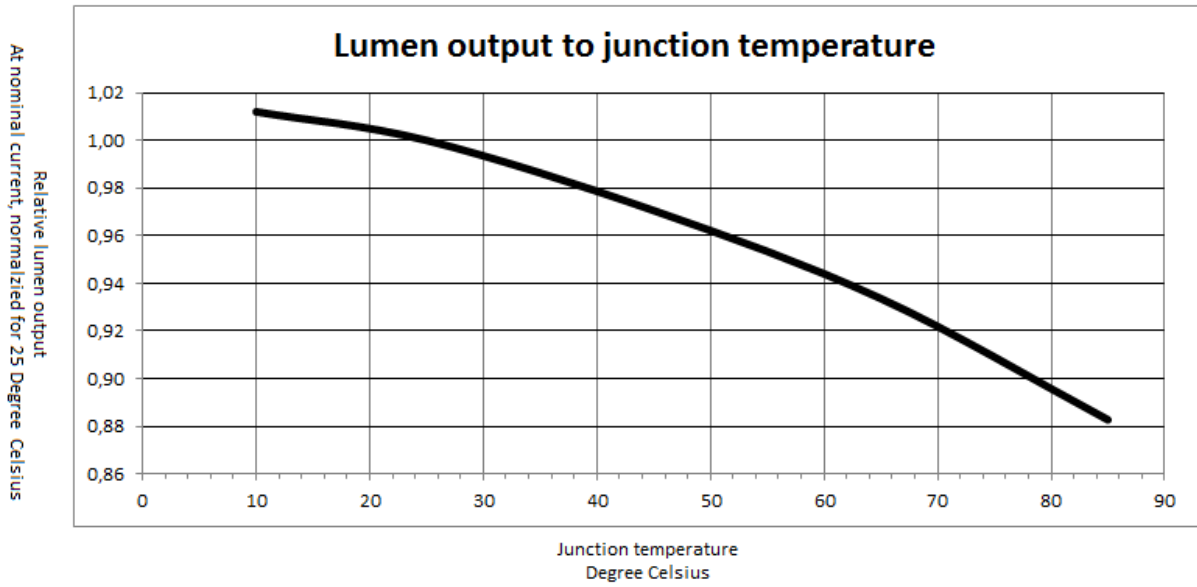

Figure 5.

Relative Luminous Flux from forward current at junction temperature 25 °C

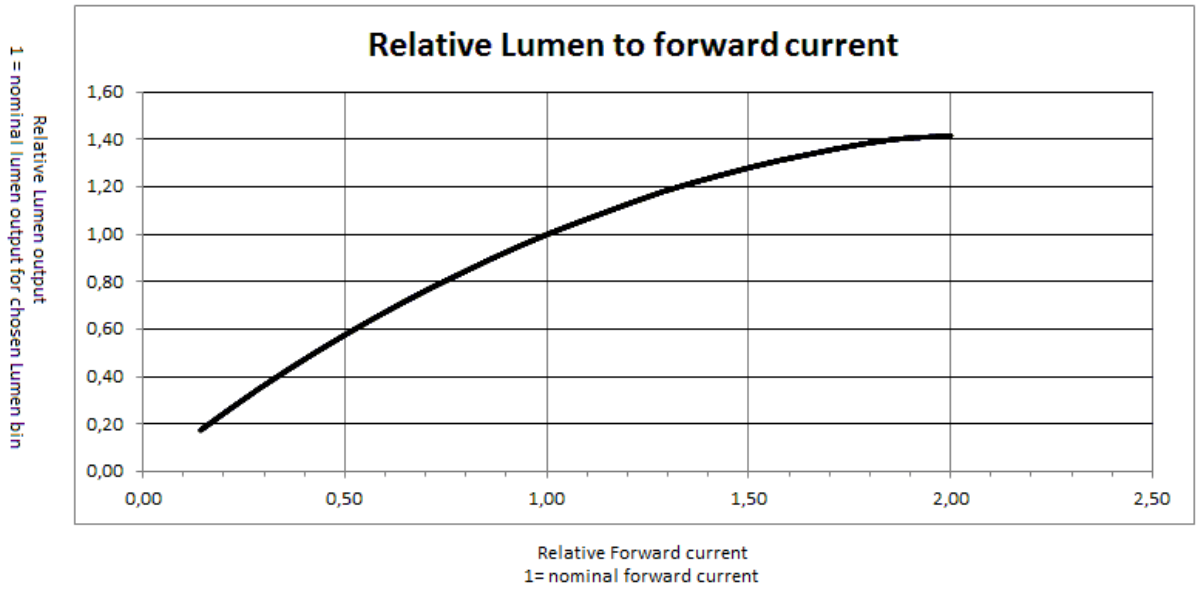

Figure 6.



Relative Lumen/W output from input power consumption at junction temperature 25 °C

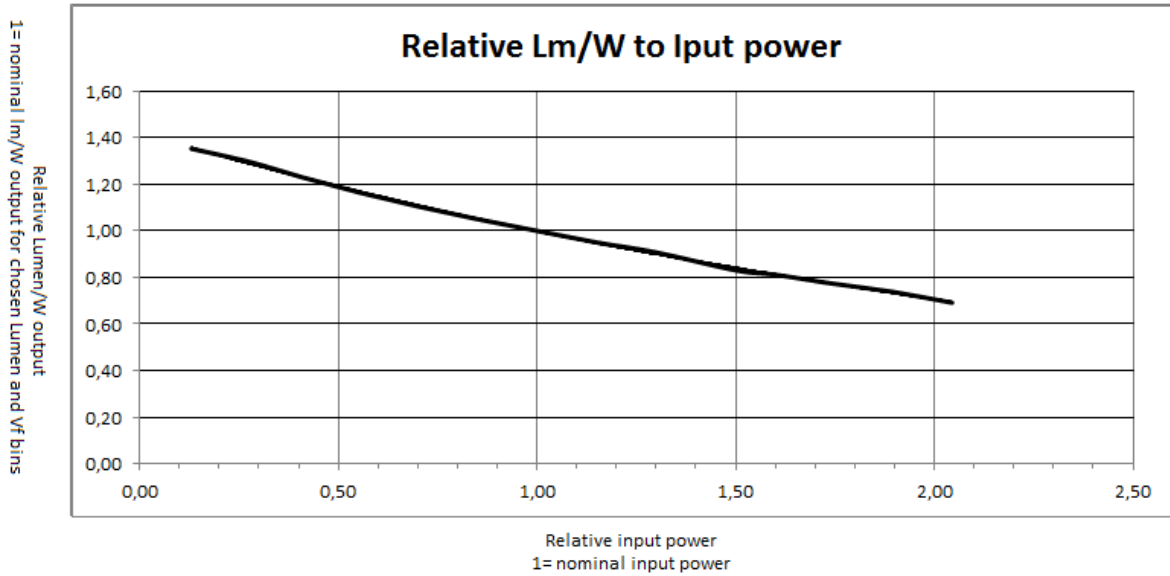

Figure 7.

Volt-Ampere characteristics at Junction temperature 25 °C

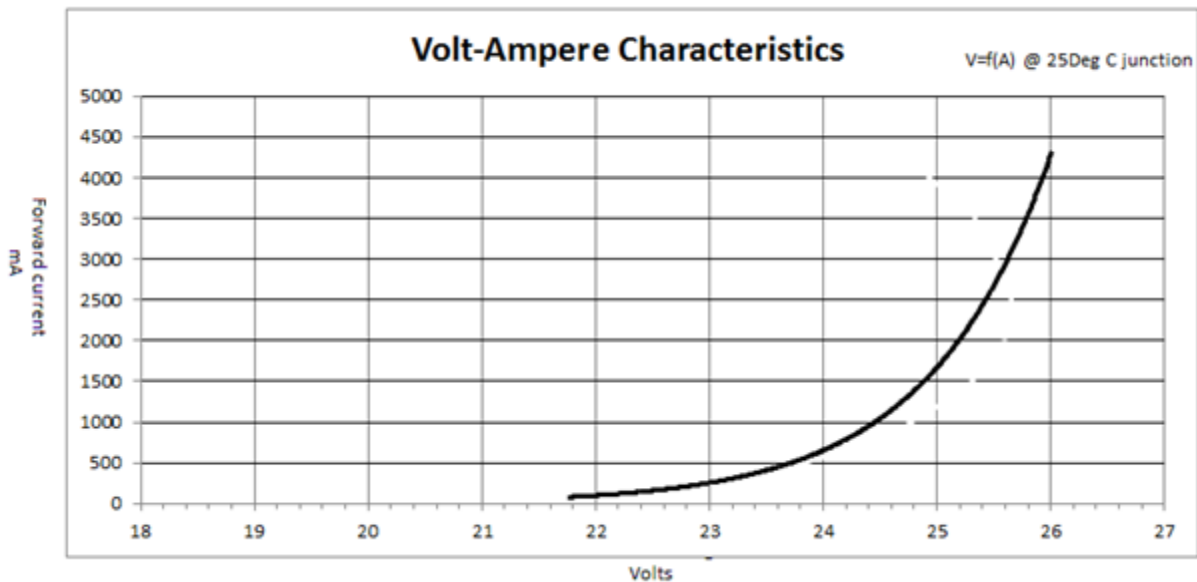

Figure 8.

Notes:

1. Octa Light maintains tolerance of $\pm 5\%$ on forward voltage measurements.
2. Proper current derating must be observed to maintain junction temperature below the maximum at all time.
3. Light Emitting Diodes are not designed to be driven in reverse bias.
4. Allowable reflow cycles are 3 times for each LED.



LED AND HOLDER DIMENSIONAL CHARACTERISTICS

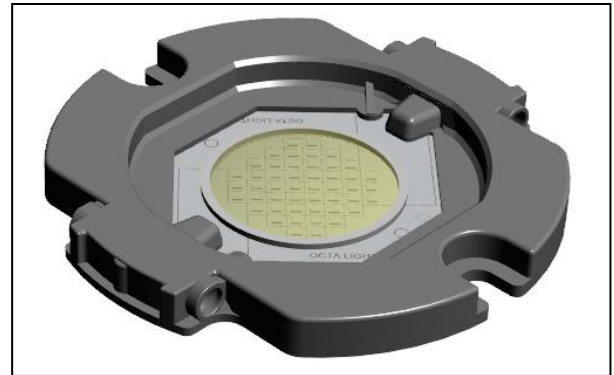
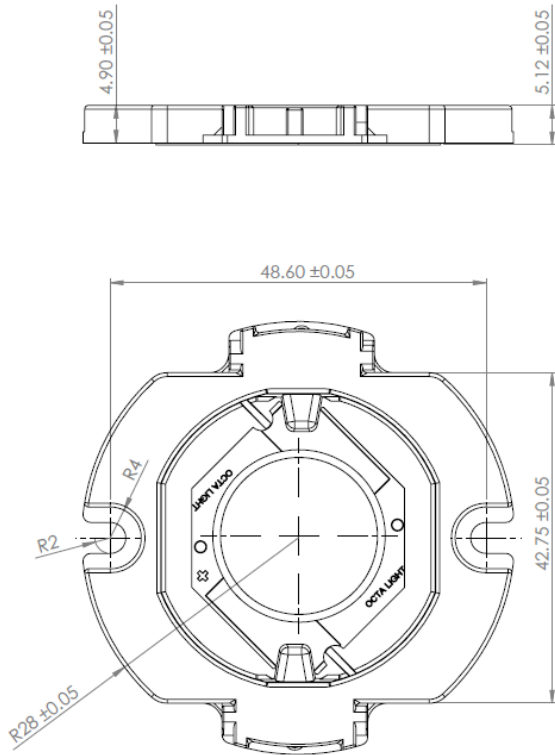

Notes:

1. All dimensions are in mm
2. Drawings are not to scale

LABELLING INFORMATION

LED PART NUMBER

ROHS DIRECTIVE COMPLIANCE

LEAD FREE MARK



INTERNAL COMPANY INFORMATION

QUANTITY



PACKING
TRAY SPECIFICATION

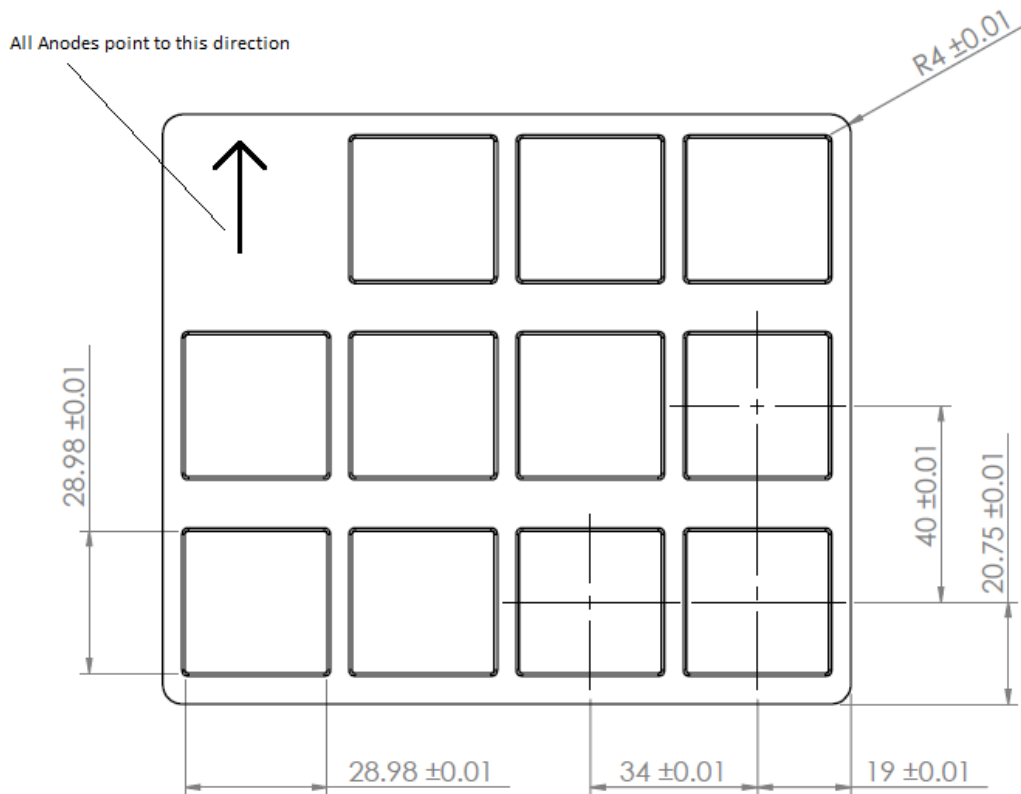
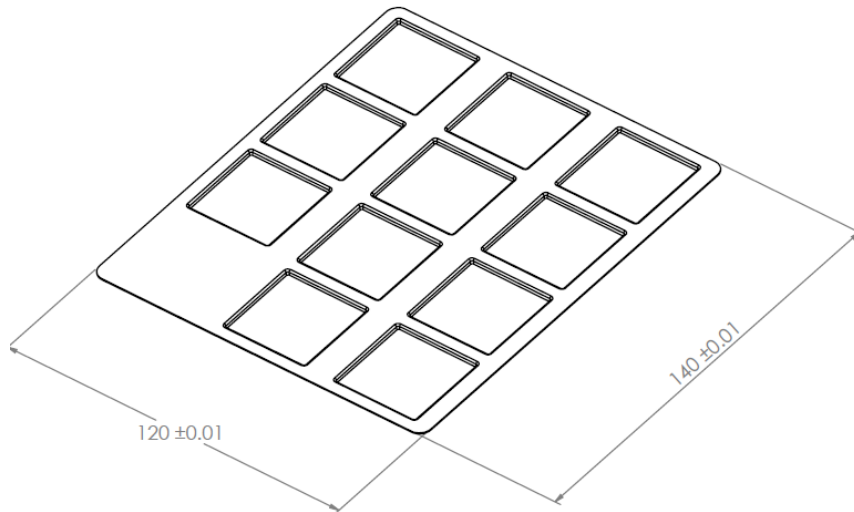

Packaging notes:

- All dimensions are in mm
- All units with same orientation within Tray.
- 11 pieces in one tray
- Tray are delivered in vacuum packed, ESD protected Bags with humidity catch pack and humidity sensor
- Only Bare LEDs and LEDs with Easysolder option are provided in trays. Holders for LEDs are provided in a separate package



PACKAGING SPECIFICATION

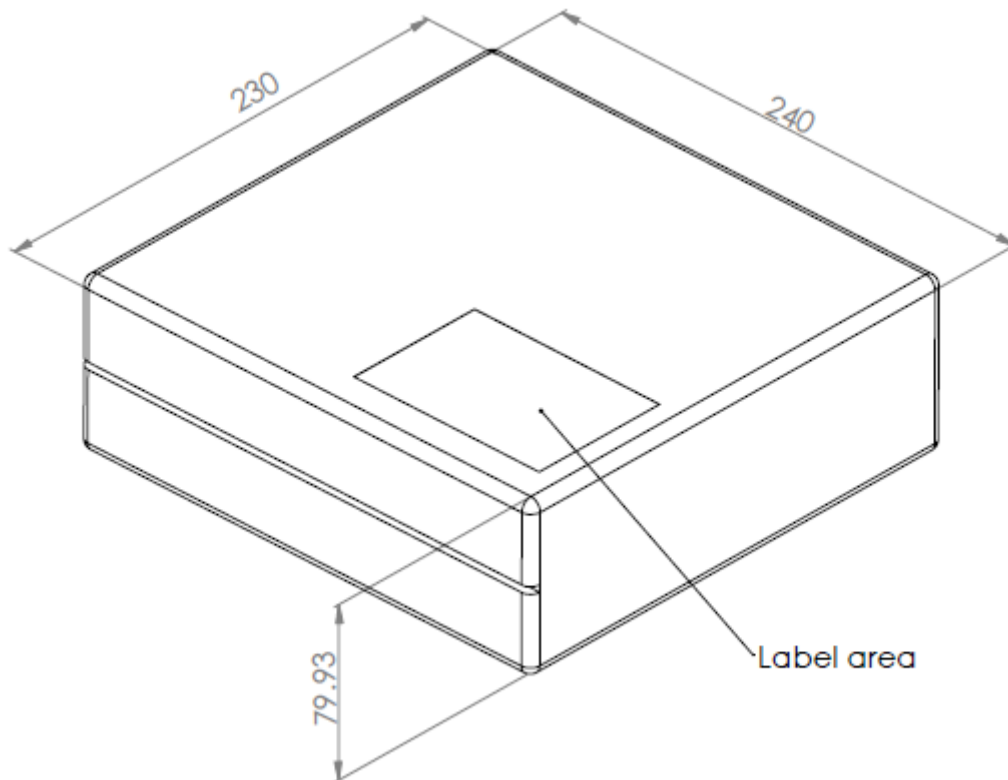

Packaging notes:

- All dimensions are in mm
- LEDs are delivered in Carton Boxes, each containing up to 5 Trays within one carton BOX.
- Label information contains the information regarding the LEDs inside each box, as well as Tray number inside

COMPANY INFORMATION

Octa Light Bulgaria Plc is the first Bulgarian Manufacturer of High Power Light Emitting Diodes for general lighting applications. The long year company experience in artificial lighting on LED basis has made possible the creation of the first European LED specially designed for reaching best performance in light output, optical efficacy and thermal management.

Octa Light Products help reduce CO₂ emissions and reduce the need for power plant expansion.

Thanks to its advanced optical properties, the BullStar series enable never before possible applications in outdoor, indoor, industrial, architectural and general lighting when pure white light is necessary. The sophisticated optical properties allow strong package light concentration suitable for most general lighting applications without the need of any secondary optics.

Octa Light is a fully integrated supplier, offering core Light emitting devices in all three base colors - red, green, blue and white, as well as exotic colors as pink, cyan, yellow, purple and other on basis of client requirements. Octa Light Bulgaria Plc is entirely based within Europe, with R&D and manufacturing centers in Bulgaria. Founded in 2010, Octa Light commits to continuously rise the lumen efficiency of its products and to bring its light emitting diodes closer to mass usage within next years.

www.octa-light.com

info@octa-light.com

©2014 Octa Light Bulgaria Plc.

All rights reserved. Product specifications are subject to change without notice. Octa Light Bulgaria and its Company signs are registered trademarks in the European Union and other countries.